

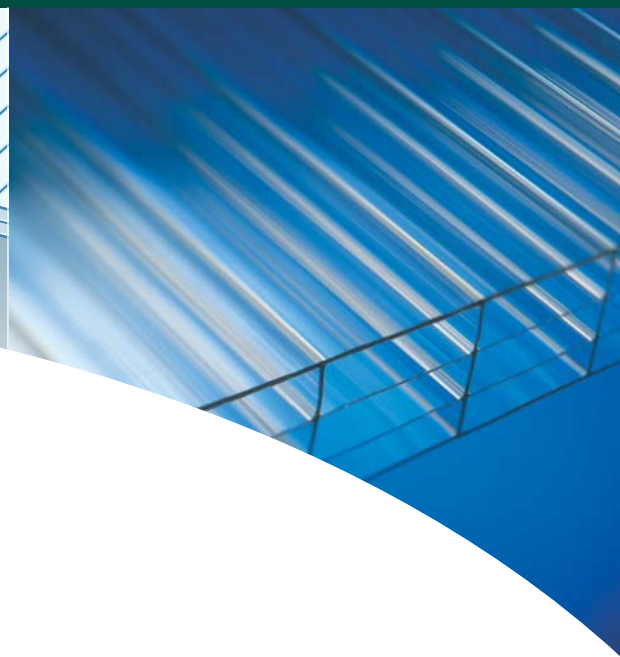

March 2007

marlon **st**

LONGLIFE

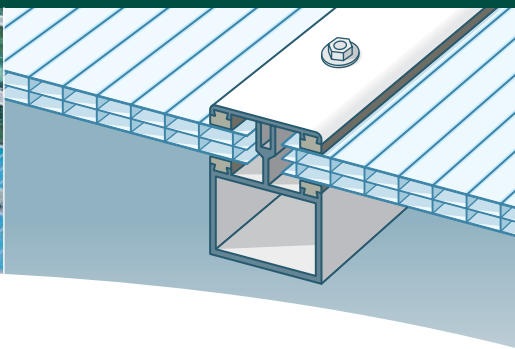

Product Guide

Structured Polycarbonate Sheet



marlon **st**

LONGLIFE

Product Guide

Brett Martin is one of the world's leading manufacturers of polycarbonate sheet, supplying material around the globe for a huge variety of applications.

Marlon ST Longlife is a premium quality structured polycarbonate sheet offering good optical clarity, exceptional impact resistance and an outstanding strength to weight ratio. It is complemented by Marlon CS Longlife and Marlon FS, corrugated and flat polycarbonate, making Brett Martin a single source for polycarbonate sheet requirements.

Brett Martin has many years of experience in the manufacture of GRP, PVC and polycarbonate sheet products. Marlon ST Longlife, as with all Brett Martin products, is manufactured under a quality management system which has earned Brett Martin BSI registered status under BS EN ISO 9001:2000

contents

PRODUCT SPECIFICATIONS & PERFORMANCE	PAGE
INTRODUCTION, PRODUCT RANGE	4
TINT OPTIONS, SOLAR HEAT GAIN	5
MATERIAL PROPERTIES	6
DURABILITY	7
IMPACT RESISTANCE	7
THERMAL PROPERTIES	8
TRANSMISSION OF LIGHT	9
CARE OF MATERIAL	9
FIRE PERFORMANCE	10
MARLON ST LONGLIFE INSTALLATION	
INSTALLATION GUIDELINES, STORAGE	13
EDGE ENGAGEMENT, CUTTING	14
THERMAL EXPANSION	15
SECURING, DRILLING & SAFETY	16
FILM REMOVAL	17
APPENDIX	
CHEMICAL RESISTANCE	19-22

PRODUCT SPECIFICATIONS & PERFORMANCE

	PAGE
INTRODUCTION, PRODUCT RANGE	4
TINT OPTIONS, SOLAR HEAT GAIN	5
MATERIAL PROPERTIES	6
DURABILITY	7
IMPACT RESISTANCE	7
THERMAL PROPERTIES	8
TRANSMISSION OF LIGHT	9
CARE OF MATERIAL	9
FIRE PERFORMANCE	10

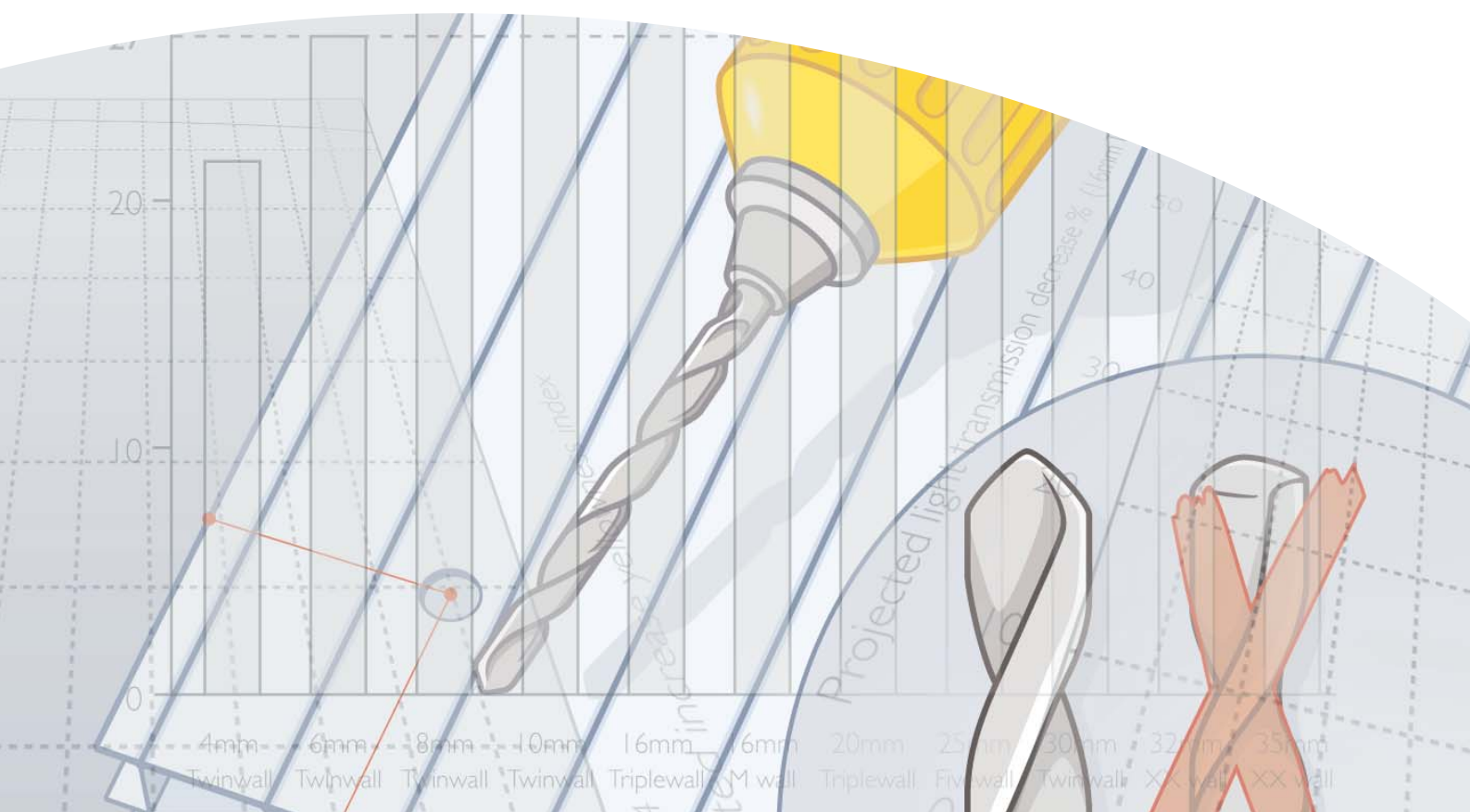

PRODUCT RANGE

Marlon ST Longlife is available in a number of thicknesses and is manufactured in twin, triple, four, five, seven, M and XX wall configurations.

Twinwall (TW) - thicknesses 4, 6, 8, 10 & 30mm



Triplewall (TRW) - thicknesses 16mm



Triplewall (TRW) - thicknesses 16 & 20mm



Fivewall (FVW) - thicknesses 16 & 25mm

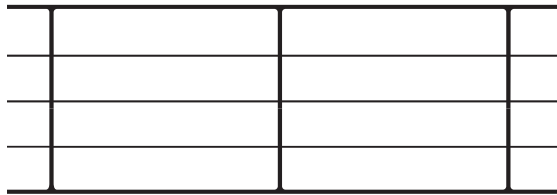

M wall (MW) - thickness 16mm

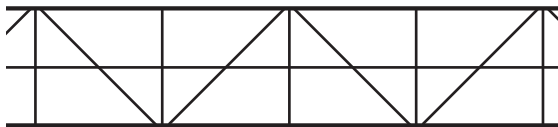

XX wall (XXW) - thicknesses 32 & 35mm

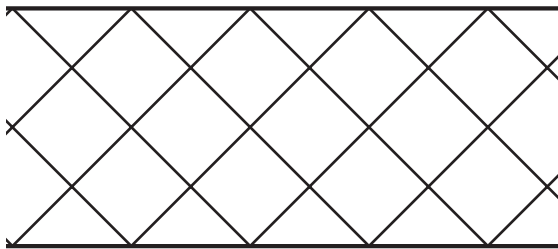

Fourwall (FW) - thickness 10 & 20mm



Sevenwall (SW) - thicknesses 32 & 35mm

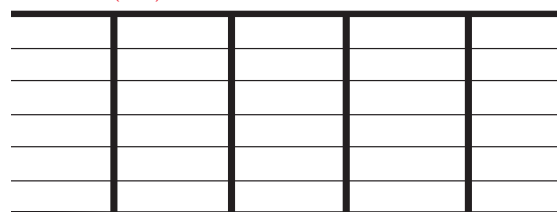

Marlon ST Longlife is a high performance polycarbonate rooflight sheet which has been designed for industrial, commercial, leisure and domestic applications where insulating glazing is required.

As the name implies, Marlon ST Longlife has impressive durability characteristics with a high degree of resistance to the harmful effects of extended usage under natural sunlight or artificial UV light conditions.

Polycarbonate has earned an excellent reputation for design flexibility, toughness, resilience, stable performance in temperature extremes, excellent fire ratings and for economy.

Marlon ST Longlife has distinct advantages over traditional glazing materials. It can be easily cut and trimmed on site, formed round gentle curves and its strength to weight ratio prevents damage in transit.

Brett Martin's confidence in the toughness and UV light resistance of Marlon ST Longlife is evident in our offering a 10 year limited warranty against yellowing and weather breakage. Please refer to the Marlon ST Longlife warranty leaflet for full details.

The purpose of this product guide is to set out the technical information on the properties of the material and to indicate the considerations involved in the recommended installation of Marlon ST Longlife polycarbonate insulating glazing.

Marlon ST Longlife an ideal material for:

- CONSERVATORY ROOFS
- WINTER GARDEN ROOFS
- CURVED ROOFLIGHTS
- ATRIUM FEATURES
- COVERED WALKWAYS
- CANOPIES & SHELTERS
- SUSPENDED CEILINGS
- WINDOWS AND DOORS
- VERTICAL GLAZING
- SWIMMING POOL COVERS
- GREENHOUSES
- INDUSTRIAL ROOFLIGHTING

TINT OPTIONS

Marlon ST Longlife is available in a wide range of colours including clear, opal, bronze, blue, green, grey and heat guard. Dual tint sheets are also available in heat guard opal, bronze opal and blue opal.

The choice of colour ultimately depends on the end result needed. Clear is used where maximisation of light is required. In order to take advantage of the heat build-up generated by the high level of light transmission clear is a popular option in colder climates. It is an ideal product for use in industrial and commercial greenhouses.

In hot climates other tint options, such as bronze, blue, green or heat guard, are more effective in limiting the amount of light and minimising glare.

Where diffusion of light is required opal is the optimum choice. Opal prevents the sunlight from concentrating on one area, therefore eliminating hot-spots while allowing light into the building to keep it bright. It is a preferred option in supermarkets where it creates a soft light quality considered by many to enhance the retail environment.

SOLAR HEAT GAIN

Some control of heat gain within a building can be achieved using glazing materials which are designed to influence the nature and quantity of transmitted light. Marlon ST Longlife with bronze and opal white tinting are both effective for solar control, reducing glare by diffusing incoming light and reducing heat gain.

Marlon ST Longlife heat guard is an innovative development in polycarbonate sheeting which limits heat build up through the sheet while transmitting light. It is ideal in any situation where natural light is required but excessive heat build up can be a problem.

*Subject to minimum order quantities, contact sales office for full details.

The heat guard option utilises a specially developed pigment to significantly reduce heat build up below the roof. Under the sun heat guard acts like a mirror to reflect the heat thus reducing solar heat gain by up to 50%, when compared to other materials. This reduction in solar heat gain can help to reduce air conditioning costs.

Heat guard opal also reduces solar heat gain by up to 50% however; the silvery grey colour is combined with an internal opal surface which creates a white finish and a soft light quality. Heat guard opal has a shading coefficient of 0.32 compared to 0.95 for clear material.

Bronze opal combines a bronze external and opal internal surface. The external bronze surface blends discretely with other roof finishes while the opal internal finish provides privacy and soft light quality. Bronze opal combines the two most popular tint options.

DOUBLE SIDED UV*

Ultra-violet protection is now available on both sides of Marlon ST Longlife, giving protection in situations where the underside of the sheet may be exposed to the sun e.g. roof vents.

ANTI DRIP*

Marlon ST Longlife, including double sided UV sheets, can be supplied with an anti-drip coating on the reverse of the sheet. This long lasting finish creates a glazing option that is resistant to condensation, ideal for use in commercial, agricultural and horticultural applications.

Tint Option	Light Transmission (%) DIN 5036 based on 25mm Fivewall	Benefit	Applications
Clear 'S'	68	Maximisation of natural daylight	Industrial & Commercial Greenhouses
Bronze 'B'	11	Cool internal environment	Walkways, Canopies, Atriums, Domestic applications
Opal 'V'	30	Diffusion of light	Supermarkets & Commercial buildings, Domestic applications
Heat Guard Opal 'EG/TU'	7	Reduction of solar heat gain by up to 50% and soft light quality internally	Domestic applications
Bronze Opal 'B/TU'	8	Privacy and soft light quality	Domestic applications
Blue Opal 'BL/PW'	7	Privacy and soft light quality	Domestic applications

TYPICAL PROPERTIES OF MARLON ST LONGLIFE

	Thickness (mm)																
	4	6	8	10	16			20		25	30	32		35			
Structure	TW	TW	TW	TW	FW	TRW	TRW	FVW	MW	TRW	FW	FVW	TW	XXW	SW	XXW	SW
Sheet thickness mm (±0.5)	4	6	8	10	10	16	16	16	16	20	20	25	30	32	32	35	35
Rib spacing (nominal) mm	6	6	10	10	12.5	16	20	20	17.5	20	20	20	35	16	20	16	20
Sheet width mm	2100	2100	2100	2100	2100	1250	2100	2100	1250	2100	1250	2100	1250	2100	2100	980	2100
Approx. weight g/m ²	800	1300	1500	1700	1700	2500	2700	2700	2800	3100	3000	3400	3500	3800	3600	4200	3900
Light transmission (%)BS4203																	
- clear S	88	88	88	88	74	82	82	73	76	79	71	68	82	64	64	63	64
- bronze B	-	55	46	46	30	31	31	28	-	31	17	15	31	-	6	-	6
- opal V	-	50	57	58	50	51	51	44	48	51	35	30	-	40	33	34	33
U-value W/m ² K	3.9	3.7	3.4	3.2	2.5		2.4	1.9	2.2	2.2	2.0	1.6	2.6	1.4	1.25	1.4	1.2
Falling dart Gardiner impact at 23°C Nm	21.3	27	>27	>27	>27	>27	>27	>27	>27	>27	>27	>27	>27	>27	>27	>27	>27

The typical properties table includes some non-standard items which may be subject to minimum order quantities and extended lead times.

TYPICAL PROPERTIES OF POLYCARBONATE RESIN

		Standard	Value	Units	
Mechanical Properties	Tensile strength at yield	DIN 53455	>60	N/mm ²	
	Tensile strength at break	DIN 53455	>70	N/mm ²	
	Elongation at yield	DIN 53455	6-8	%	
	Elongation at break	DIN 53455	>100	%	
	Modulus of elasticity	DIN 53457	>2300	N/mm ²	
	Notched impact strength	DIN 53453	>50	kJ/m ²	
Physical Properties	Specific gravity	DIN 53479	1.20	g/m ³	
	Refractive index nD25	DIN53491	1.585		
	Water absorption, 24h @ 23°C	DIN 53495	0.35	%	
	Water permeability (thickness 1mm)	DIN53122	<2.28	g/m ²	
Thermal Properties	Softening temperature Vicat 'B'	DIN 53460	145-150	°C	
	Deflection temperature, load 1.81N/mm ²	DIN 53461	140-145	°C	
	Linear thermal expansion	DIN 53752	6.7x10 ⁻⁵	m/m°C	
	Thermal conductivity (λ-value)	DIN 52612	0.2	W/m°C	
	Maximum service temperature - no loading			Permanent 100	°C
				Short Term 130	

Measured on injection moulded test specimens.

SOUND REDUCTION INDEX

MARLON ST SHEET	SOUND REDUCTION INDEX* (dB)
4mm Twinwall	6
6mm Twinwall	8
8mm Twinwall	13
10mm Twinwall	20
10mm Fourwall	20
16mm Triplewall ^a	21
16mm Fivewall	21
16mm M wall	21
20mm Triplewall	22
20mm Fourwall	22
25mm Fivewall	23
30mm Twinwall	25
32mm XX-wall	25
32mm Sevenwall	25
35mm XX-wall	25
35mm Sevenwall	25

* Airborne Sound Reduction Index to BS EN ISO 140-3: 1995, BS2750: Part 3

^a 16TRW with 20mm and 16mm rib spacing

(4mm Single Glazing – 27dB, 4+4mm Double Glazing – 25dB)

RESISTANCE TO UV LIGHT

UV light has two potentially harmful effects on polycarbonate; a yellowing of the material itself and a degradation of mechanical properties, eg. resistance to impact. Marlon ST Longlife's surface, which has a high performance co-extruded protection system, has a high degree of resistance to the effects of natural and artificial UV light sources minimising long term yellowing and maintaining durability and toughness.

UV LIGHT ABSORPTION LAYER

Marlon ST Longlife has a high performance UV absorption layer co-extruded on the outer surface. This UV absorption layer forms a barrier to incident UV radiation, preventing it penetrating to the body of the sheet material, so that long term yellowing and loss of mechanical properties, eg. impact strength, are negligible.

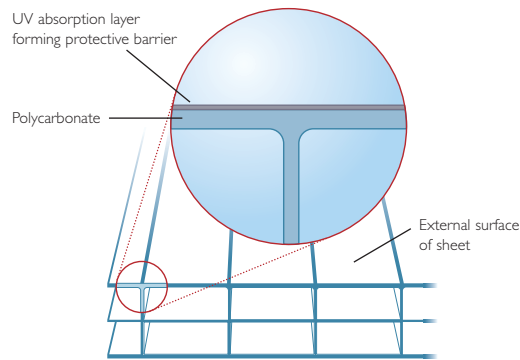

Marlon ST Longlife cuts out 98% of harmful UV radiation, protecting those working or playing beneath it.

LOSS OF LIGHT TRANSMISSION, INCREASE IN YELLOWNESS INDEX

Testing shows negligible degrading of the material's light transmission properties or yellowing and a retention of its inherent strength and resistance to impact.

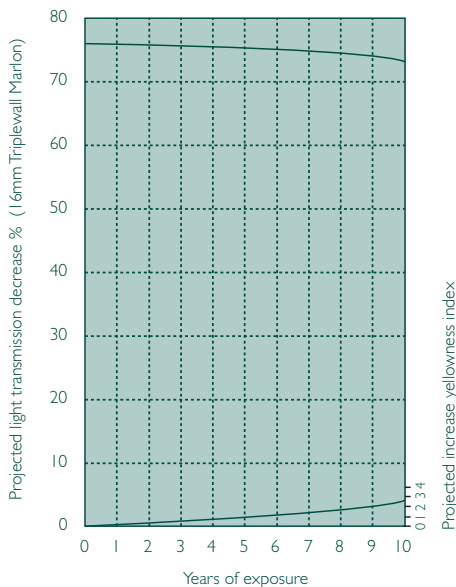

This confirms Marlon ST Longlife as a most advanced insulating glazing material for exterior installations with numerous advantages over traditional glazing materials.

All Marlon ST Longlife sheeting has its UV resistant surface clearly indicated by the removable, branded, protective film and this should face outwards when installed.

Its intrinsic impact durability and optical clarity combined with its valuable energy conserving properties make Marlon ST Longlife a very popular material for use in roof glazing, rooflights, windows, doors, partitions and suspended ceilings.

RESISTANCE TO HAIL DAMAGE

Damage to glazing materials, particularly those installed in roofs, occurs when hail storms contain hailstones 20-30mm diameter; having an impact velocity 21-25mm/sec. When Marlon ST Longlife of thickness 10mm and above is used in roof glazing, it is unlikely that any cracks will be caused by such hail storms over a wide range of service temperatures and long service life.

RESISTANCE TO IMPACT

The resistance of Marlon ST Longlife to impact damage is assessed using the Gardiner Falling Dart Impact Test.

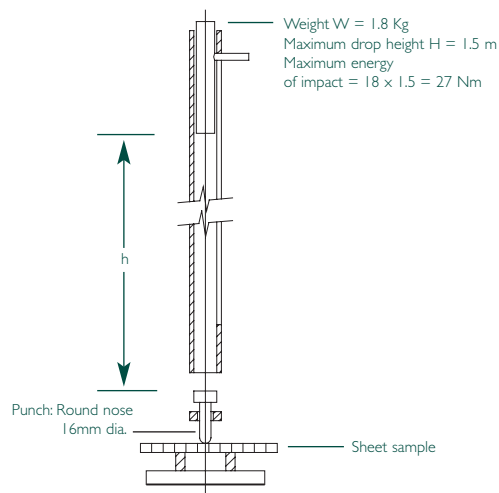

Marlon ST Longlife exhibits excellent resistance to impact damage over a broad service temperature range and prolonged service life. The fact that this resistance is superior to that of other glazing materials means superior resistance to breakage in handling, transport, installation and during its service life.

RESISTANCE TO IMPACT

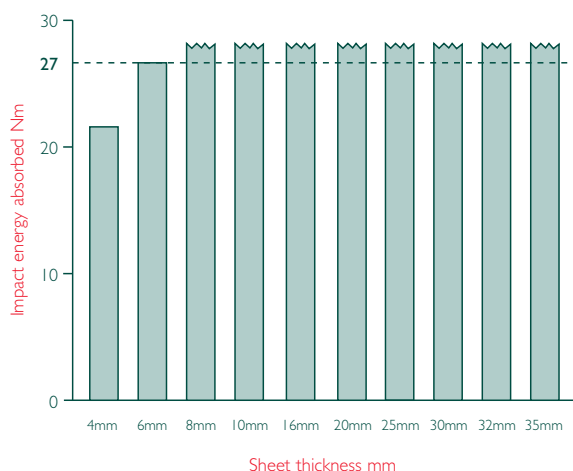

COMPARATIVE WEIGHTS

Marlon ST Longlife has a very high strength to weight ratio. As the self weight is therefore very low, support structures do not need to be quite so heavy as in the case of, for example, glass. Consequently there are savings to be gained in terms of structure costs as well as installation and labour savings when Marlon ST Longlife is used.

COMPARATIVE WEIGHTS OF GLAZING MATERIALS kg/m²

Thickness (mm)	Marlon ST Longlife	Single Glass	Double Glass	Twinwall Acrylic
4 TW	0.8	10	20	-
6 TW	1.3	15	-	-
8 TW	1.5	20	-	-
10 TW	1.7	25	-	-
10 FW	1.7	-	-	-
16x16 TRW	2.5	-	-	-
16x20 TRW	2.5	-	-	-
16 TRW	2.7	40	-	5.2
16 FVW	2.7	-	-	-
16 MW	2.8	40	-	-
20 TRW	3.1	-	-	-
20 FW	3.1	-	-	-
25 FVW	3.4	62.5	-	-
30 TW	3.5	-	-	-
32 XXW	3.8	-	-	6.5
32 SW	3.7	-	-	-
35 XXW	4.2	-	-	-
35 SW	3.9	-	-	-

SERVICE TEMPERATURE

Marlon ST Longlife can be installed in a diversity of applications, with varying temperatures. However, the material's mechanical performance is known to remain stable in prolonged service in temperatures ranging from -40°C to +100°C. PVC has a maximum service temperature of 60°C whilst that of acrylic is 80°C.

THERMAL EXPANSION

The coefficient of linear expansion of polycarbonate material is $6.7 \times 10^{-5} \text{m/m}^\circ\text{C}$. This is high relative to that of most other materials in conjunction with which it is normally used. As a consequence careful allowance must be made for the thermal expansion of Marlon ST Longlife sheets, both longitudinally and laterally. The graph on page 14 shows the expansion allowances that must be made for given lengths and widths of sheet.

INSULATION

A considerable advantage of Marlon ST Longlife, particularly in colder regions is that it is much more efficient at preventing excessive heat loss than traditional glazing materials of comparable thickness.

With the emphasis firmly on energy conservation in modern building practice in Northern Europe, Marlon ST Longlife polycarbonate insulating glazing can be a great asset to the architect and specifier; particularly in colder regions. The Relative U-values table compares the insulation properties of Marlon ST Longlife with other glazing types.

RELATIVE U-VALUES W/m²K

Sheet Thickness (mm)	Marlon ST Longlife	Single Glass	Double Glass	Argon Filled Cavity
4 TW	3.9	5.8	2.65	1.6
6 TW	3.7	-	-	-
8 TW	3.4	5.7	2.65	1.6
10 TW	3.2	5.7	2.65	1.6
10 FW	2.5	-	2.65	1.6
16 TRW*	2.4	5.5	2.65	1.6
16 FVW	1.9	-	2.65	1.6
16 MW	2.2	-	2.65	1.6
20 TRW	2.2	-	2.65	1.6
20 FW	2.0	-	2.65	1.6
25 FVW	1.6	-	2.65	1.6
30 TW	2.6	-	2.65	1.6
32 XXW	1.4	-	2.65	1.6
32 SW	1.25	-	2.65	1.6
35 XXW	1.4	-	2.65	1.6
35 SW	1.2	-	2.65	1.6

* 16TRW with 20mm and 16mm rib spacing

SPECTRAL TRANSMISSION OF POLYCARBONATE SHEETING

Polycarbonate sheet is transparent to wavelengths of light between 385nm at the lower limit and approximately 5000nm at the upper limit. Importantly polycarbonate is opaque to infra-red radiation: light in the visible spectrum entering a building is absorbed by the interior and contents and re-radiated as long wave infra-red radiation, which cannot be re-transmitted back through the polycarbonate sheeting.

Consequently in addition to being an excellent insulating material Marlon ST Longlife also retains heat inside buildings due to the greenhouse effect which it creates.

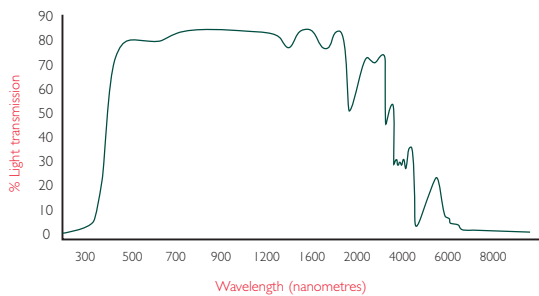

TRANSMISSION REFLECTION AND ABSORPTION OF LIGHT BY POLYCARBONATE SHEETING

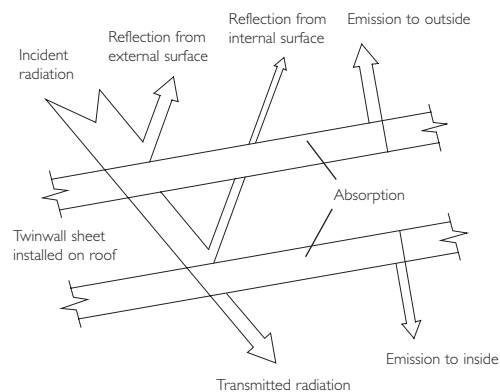

CLEANING

As a condition of ensuring that Marlon ST Longlife performs at optimum throughout its service life, it is recommended that the sheet be cleaned periodically using suitable household cleaning agents. The recommended cleaning instructions are as follows:

- use lukewarm water to rinse sheet and soften dirt
- make up a solution of lukewarm water and ordinary household cleaner or a mild soap and use this to wash sheet
- a sponge or soft cloth should then be used to gently remove dirt and grime
- the cleaning process should then be repeated and the sheet rinsed and dried with a soft cloth

WARNING!

Care should be taken to observe the following precautions:

1. Do not scrub Marlon ST Longlife sheet with brushes or sharp instruments.
2. Avoid contact with the UV protected surface of Marlon ST Longlife by Butyl Cellosolve, Isopropanol or any other solvent.
3. Avoid any abrasives or cleaners of a highly alkaline composition.

It is generally advisable in all instances to test any cleaner on a sample piece of Marlon ST Longlife first and it should also be remembered that cleaners and solvents which state that they are suitable for cleaning polycarbonate may not be safe for use on the UV protective surface of Marlon ST Longlife.

FIRE PERFORMANCE

The fire performance of Marlon ST Longlife has been independently tested and the following classifications obtained.

Country	Thickness	Colour	Classification
Germany	8mm Twinwall	Clear	Pass
	10mm Twinwall	Clear; Opal	Class B1
	16mm Triplewall	Clear; Opal	Class B1
	16mm M-wall	Clear; Opal	Pass
	25mm Fourwall	Clear	Pass
	25mm Fivewall	Clear; Bronze	Class B1
Italy	6mm Twinwall	Clear	Class 1
	10mm Twinwall	Clear	Class 1
	16mm Triplewall	Clear	Class 1
	25mm Fivewall	Clear	Class 1
Belgium	10mm Twinwall	Clear	Class A1
	16mm Triplewall	Clear	Class A1
France	6mm Twinwall	Clear	M1
	8mm Twinwall	Clear	M1
	10mm Twinwall	Clear; Bronze,	M1
	10mm Twinwall	Opal, Heat Guard	M2
	16mm Triplewall	Clear; Opal, Bronze, Heat Guard Opal	M2
	16mm M-wall	Clear; Opal	M2
	20mm Triplewall	Clear	M2
	25mm Fivewall	Clear; Opal, Bronze, Heat Guard Opal	M2
	30mm XX-wall	Clear; Opal, Heat Guard Opal, Pearlescent	M2
Holland	10mm Twinwall	Clear	Class 1
	16mm Triplewall	Clear	Class 2
	25mm Fivewall	Clear	Class 2
Hungary	6mm Twinwall	Clear	Pass
	8mm Twinwall	Clear	Pass
	10mm Twinwall	Clear	Pass
	16mm Twinwall	Clear	Pass
	16mm Triplewall	Clear	Pass
	20mm Triplewall	Clear	Pass
	25mm Fivewall	Clear	Pass
Poland	4mm Twinwall	Clear	Pass
	6mm Twinwall	Clear	Pass
	8mm Twinwall	Clear	ISO 1195/1383
	10mm Twinwall	Clear	ISO 1195/1383
	16mm Triplewall	Clear	ISO 1195/1383
	16mm M-wall	Clear	ISO 1195/1383
	20mm Triplewall	Clear	ISO 1195/1383
	20mm Fourwall	Clear	ISO 1195/1383
	25mm Fivewall	Clear	Pass
	30mm Twinwall	Clear	Pass
	Canada	10mm Twinwall	Clear
16mm Triplewall		Clear	C 2
25mm Fivewall		Heat Guard Opal	Pass
Australia	8mm Twinwall	Clear	Pass

Table continued overleaf

FIRE PERFORMANCE (Cont'd)

Country	Thickness	Colour	Classification
Romania	4mm Twinwall	Clear	Pass
	6mm Twinwall	Clear	Pass
	8mm Twinwall	Clear	Pass
	10mm Twinwall	Clear	Pass
	16mm Triplewall	Clear	Pass
	20mm Triplewall	Clear	Pass
	25mm Fivewall	Clear	Pass
	32mm XX-wall	Clear	Pass
Czech Republic	4mm Twinwall	Clear	Pass
	6mm Twinwall	Clear	Pass
	8mm Twinwall	Clear	Pass
	10mm Twinwall	Opal	Pass
	16mm Triplewall	Clear	Pass
	20mm Triplewall	Clear	Pass
	25mm Fivewall	Clear	Pass
	32mm XX-wall	Clear	Pass
UK	10mm Twinwall	Clear	Class 1 Y
	10mm Fourwall	Clear	Pass
	16mm Triplewall	Clear	I = 11.1, I = 4.5
	16mm Triplewall	Clear, Opal, Bronze, Heat Guard, Heat Guard Opal, Bronze	Class 1 Y
	25mm Fourwall	Clear	1 Y
	25mm Fivewall	Clear	1 Y
	25mm XX-wall	Clear	1 Y
	35mm XX-wall	Clear	2 Y
	35mm Sevenwall	Clear	1 Y

Brett Martin have a continuing programme of fire testing as additions to the product range become available
 - please contact Brett Martin for the most recent update.

INSTALLATION GUIDE

	PAGE
STORAGE, INSTALLATION GUIDELINES,	13
SEALANTS, TAPES, EDGE ENGAGEMENT, CUTTING	14
THERMAL EXPANSION	15
SECURING SHEET	16
FILM REMOVAL, SAFETY	17

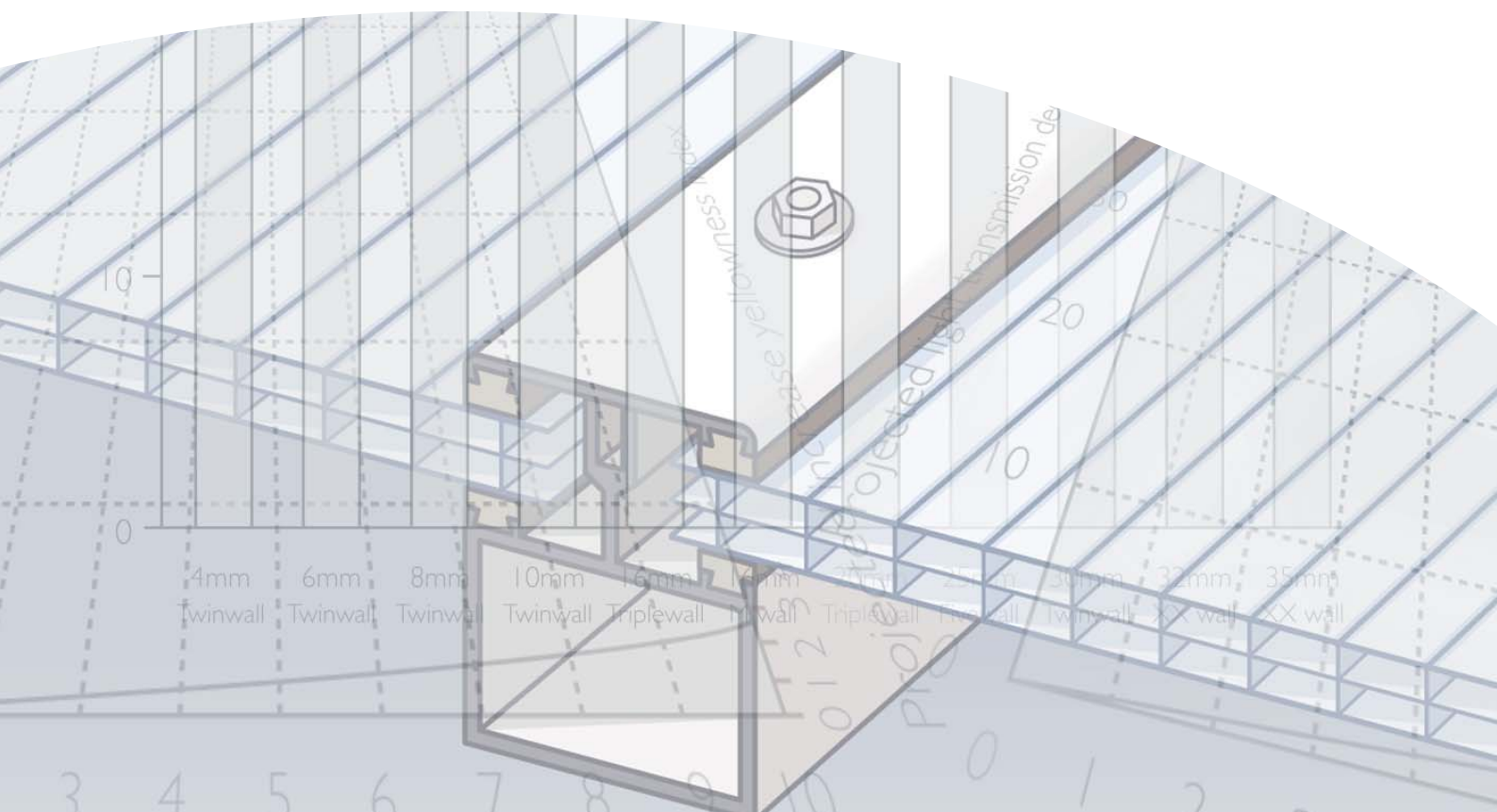

STORAGE

Store sheets on flat surfaces or wooden bearers with 100mm minimum bearing surface placed at centres not exceeding 1m. Use an opaque cover; tightly secured, to protect from wind, rain and sun. Storage is always preferable indoors.

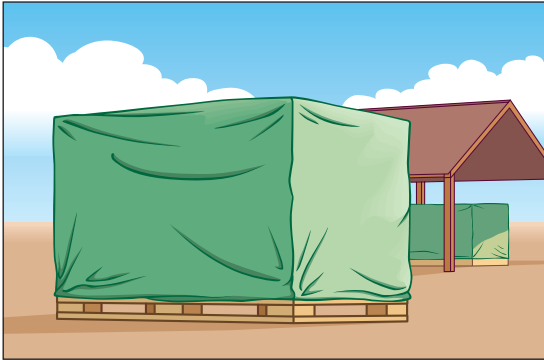

INSTALLATION SYSTEMS

Marlon ST Longlife can be installed using many of the currently available glazing systems designed for structured glazing sheets of PVC, acrylic and polycarbonate material. The diagrams illustrate the principle parts.

SUPPORTED GLAZING BAR SYSTEM

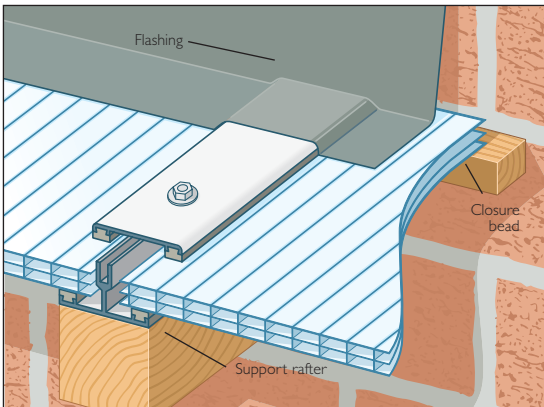

SELF SUPPORTING GLAZING BAR SYSTEM

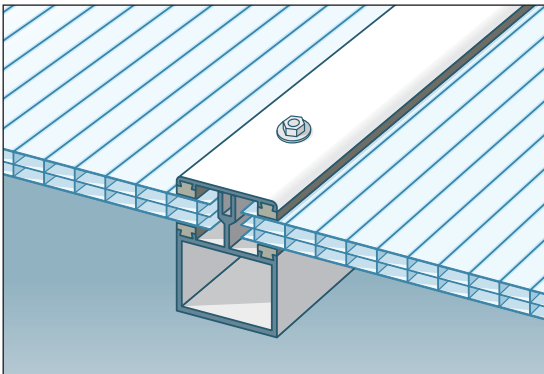

END WALL ABUTMENT

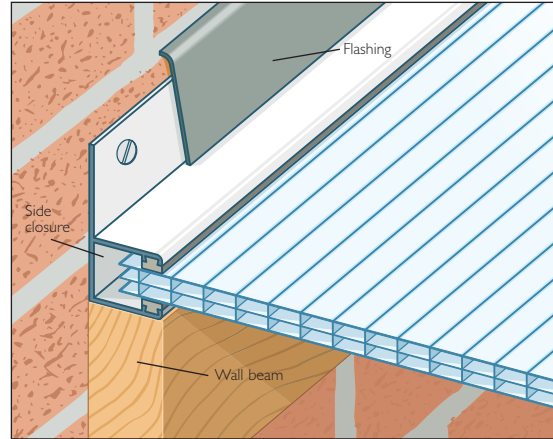

GABLE CLOSURE

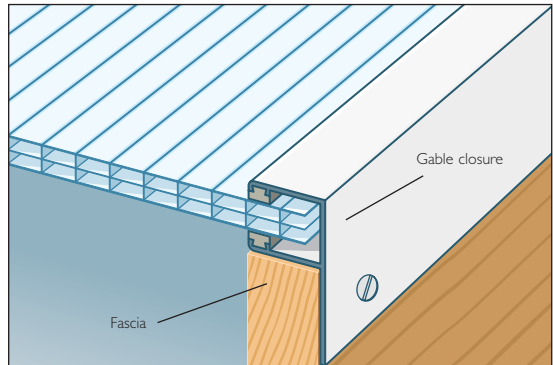

Marlon ST Longlife is robust yet lightweight. Installation is straightforward but it is **IMPERATIVE** that the following **RULES** are applied to **EVERY** installation. These rules must read in conjunction with the fitting instructions for the glazing bar system being used.

- Roofs should always be designed with a minimum slope of 5° to allow adequate rainwater run-off.
- Fitting of Marlon ST Longlife polycarbonate sheets should be the last operation in completing the project. The structure should be finished with all components of the selected glazing system in place and wood preservatives, when used, thoroughly dry.
- **Marlon ST Longlife sheets must always be installed with the ribs running vertically, or up-slope.**
- Ensure that the clearly marked UV protected surface of the Marlon ST Longlife sheet is to the outside. About 50mm of protective film should be peeled back from the edges of the sheet prior to application and the residual film removed after glazing is complete.

SEALANTS

Always ensure that sealants, gaskets and other materials used with Marlon ST Longlife do not have a detrimental effect on the material. **A low-modulus neutral silicone MUST be used as an all-purpose silicone will cause polycarbonates to crack and disintegrate.**

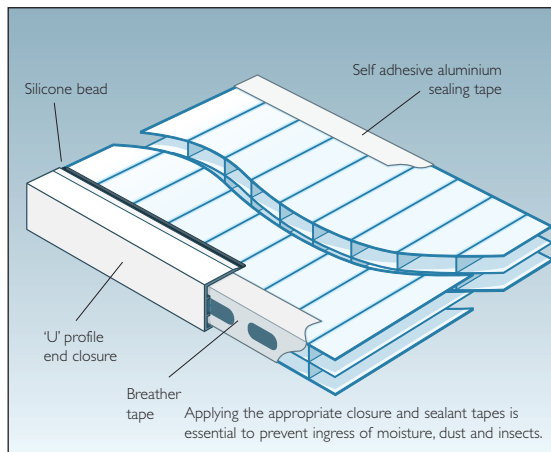

TAPES

The diagram above shows the correct orientation of Marlon ST Longlife sheet in application and the positioning of the tapes. A sealing tape, preferably aluminium, is applied at the top of the sheet to prevent ingress of moisture, dust and insects. A breather tape applied to the bottom end of the sheet permits air to move freely in and out of the sheet, helping minimise condensation by equalisation of the air vapour pressure inside and outside the sheet. The breather tape also prevents dust or insects entering the sheet. The breather tape must be covered with a 'U' profile, sealed to the top face of the sheet with a small silicone bead to protect both the tape and the lower end of the sheet from rainwater run-off.

Allowing air movement through the breather tape does not reduce the insulation performance. Following these procedures reduces the risk of condensation, water ingress and the growth of algae within the sheet.

Drainage of condensed water vapour is facilitated by installing the sheet with its ribs running in the direction of the slope.

Marlon ST Longlife sheet has been proven to be suitable for use with a substantial number of commercially available glazing compounds, building materials and profile systems. However, it is still vital that advice on chemical compatibility should be sought either from Brett Martin's Technical Department or the manufacturer of interfacing products.

EDGE ENGAGEMENT

To ensure optimum security under load it is imperative that at least one vertical rib of the sheet is engaged and securely clamped in the glazing system. This is most easily achieved when sheets have closed edges.

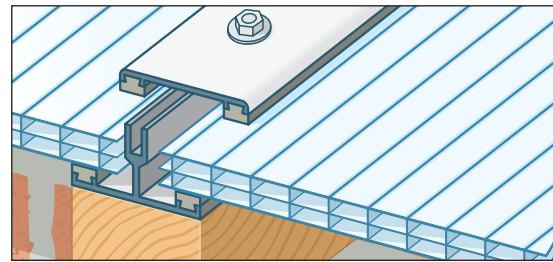

Where open edge sheets are used the sheet must be cut as closely as possible to the rib thus minimising the unsupported top and bottom faces. Glazing systems of adequate width to provide sufficient engagement must be selected.

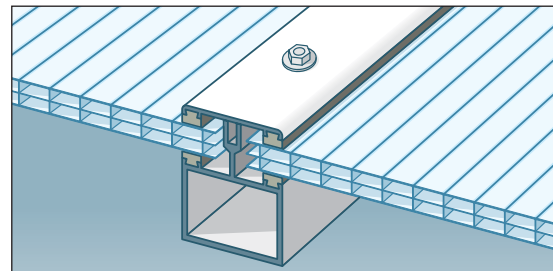

CUTTING

Marlon ST Longlife can be cut with a fine tooth circular saw or hand saw held at a shallow angle. Dust **MUST** be removed from the sheet using a vacuum cleaner or dry compressed air.

It is necessary to support the sheet close to the cut and to hold it firmly to prevent stress and vibration.

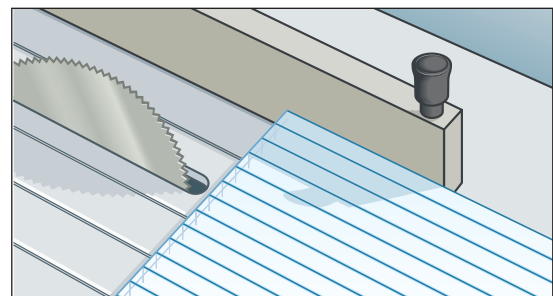

	Circular Saw	Bandsaw
Clearance angle	20-30°	20-30°
Rake angle	15°	0.5°
Cutting speed	180-250 m/min	200-250 m/min
Blade speed	1800-2400 m/min	-
Tooth spacing	2-5 mm	1.5-2.5 mm

THERMAL EXPANSION

Accommodating the thermal expansion of Marlon ST Longlife sheet cannot be over emphasised as this is generally greater than that of other popular glazing materials and affects both length and width.

	Linear thermal expansion
Marlon ST Longlife	$6.7 \times 10^{-5} \text{ m/m}^\circ\text{C}$
PVC	$6.8 \times 10^{-5} \text{ m/m}^\circ\text{C}$
Acrylic	$7.0 \times 10^{-5} \text{ m/m}^\circ\text{C}$
Aluminium	$2.3 \times 10^{-5} \text{ m/m}^\circ\text{C}$
Steel	$1.2 \times 10^{-5} \text{ m/m}^\circ\text{C}$
Glass	$0.85 \times 10^{-5} \text{ m/m}^\circ\text{C}$

Comparison of the linear thermal expansion of Marlon ST Longlife with other common materials.

Installing without sufficient allowance for thermal movement will result in thermal stress and bowing of the sheet.

The table above compares the linear thermal expansion of Marlon ST Longlife with other common materials. In practical terms it is necessary to allow 3.5mm/metre length and width for thermal expansion. The graph below shows the amount of thermal expansion allowance which must be made for given lengths and widths of sheet.

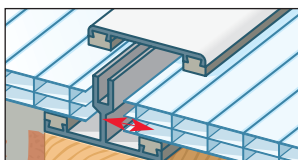
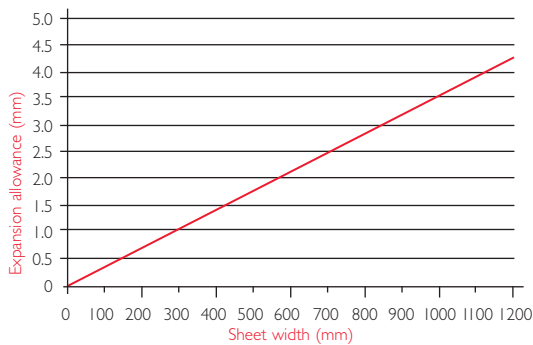
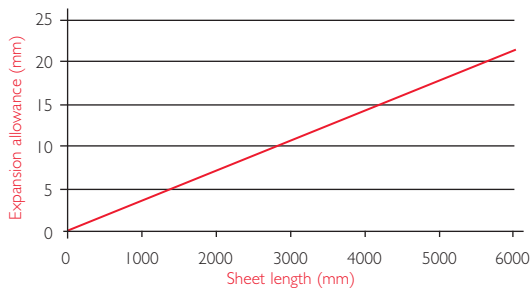

Sufficient allowance for thermal movement must be made in all glazing bars, side and end closures.

Example: If the sheet length is 1000mm allow 3.5mm minimum for thermal expansion at the top. For sheets that are 6000mm long allow 21mm for thermal expansion at the top.

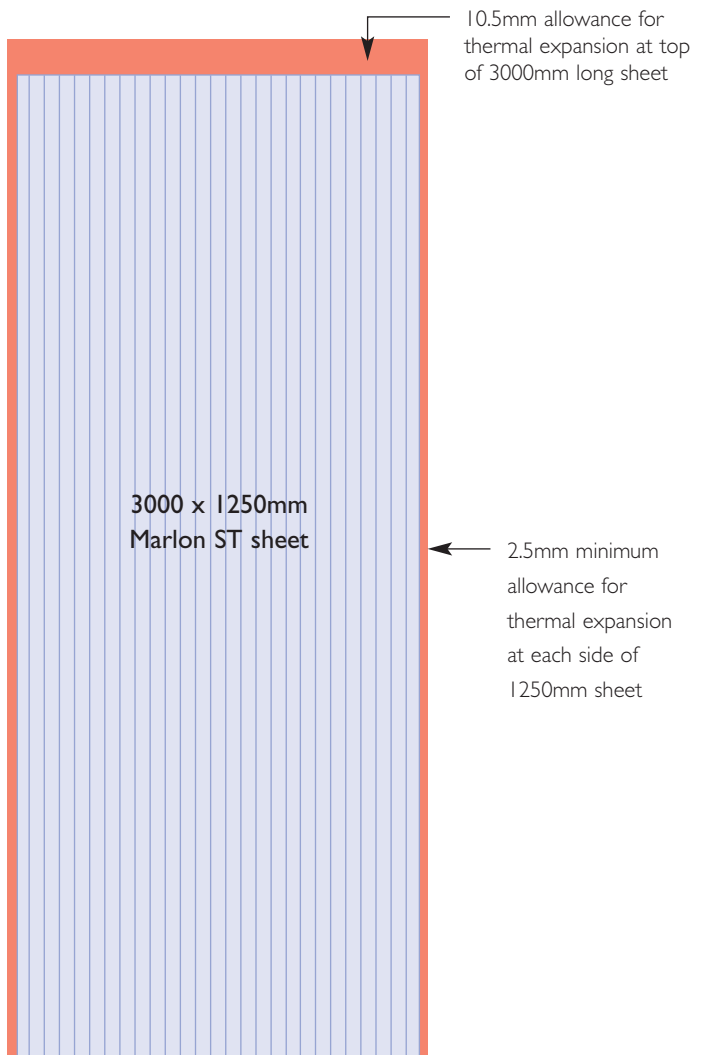
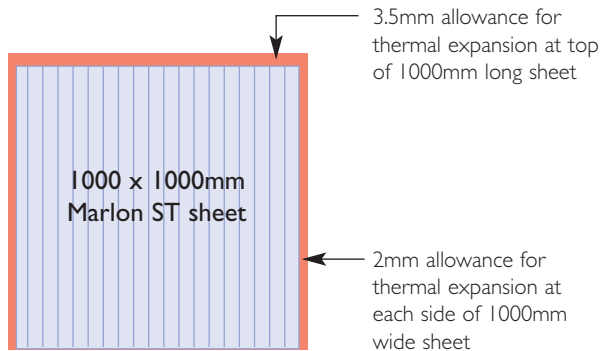

SECURING SHEET

Sheets must not be fixed or clamped too tightly as this will prevent thermal expansion and contraction and will adversely affect the installation.

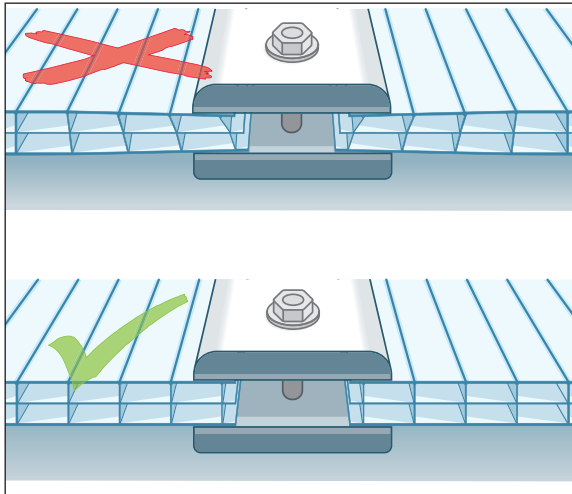

At the eaves purlin additional fixing is necessary to prevent wind uplift and downslope slippage due to repeated thermal movement. One button per sheet width, centrally located between glazing bars should be sufficient. Holes for cladding buttons should be 18mm in diameter:

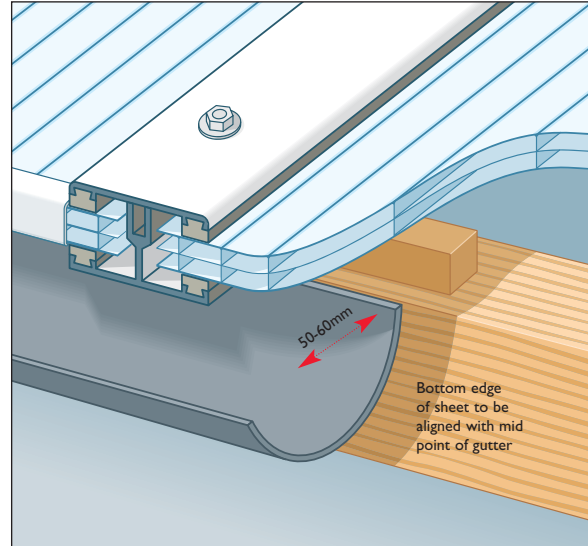
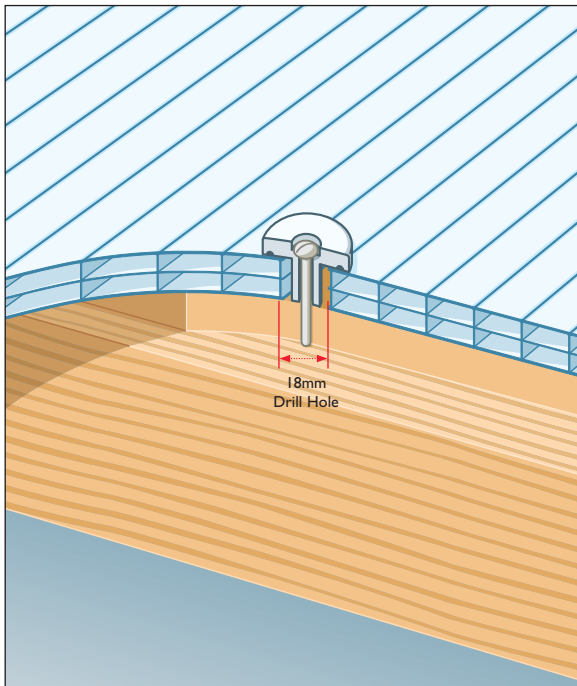

The maximum overhang of the end of the sheet should be 50-60mm. This will ensure proper run off of rainwater into the gutter.

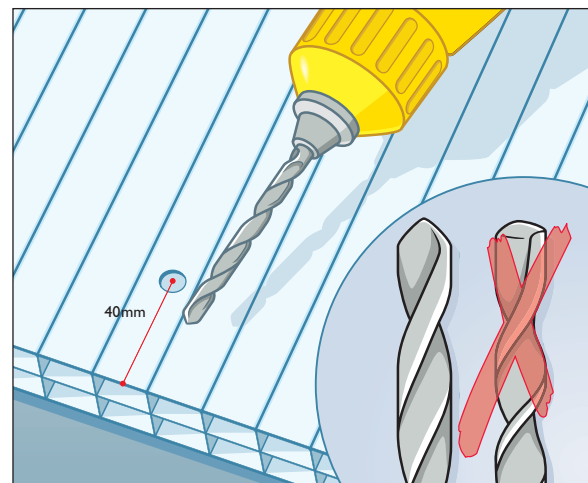

Drill between ribs. **When drilling Marlon ST Longlife use standard twist drills and carbide tipped drills.**

The sheet must be supported firmly underneath when drilling. Holes must not be drilled any less than 40mm from the edges of the sheet.

A successful polycarbonate installation must satisfy load conditions, remain weathertight at all times and have one fixed point from which there can be unrestricted thermal movement in length and width.

FILM REMOVAL

The UV protected surface of Marlon ST Longlife is covered at manufacture with a branded film. This should always be on the outside of the installation.

A further plain film is applied to the inner surface. To install, the films should be peeled back about 50mm to allow clean sheet insertion into the glazing system and application of end tapes and closure.

Both films should be left in place for protection of the sheet until project hand over, particularly when there are following trades and then they can be removed. If the project is likely to take time to complete, regularly check that the film does not bond on to the sheet, particularly in sunny weather.

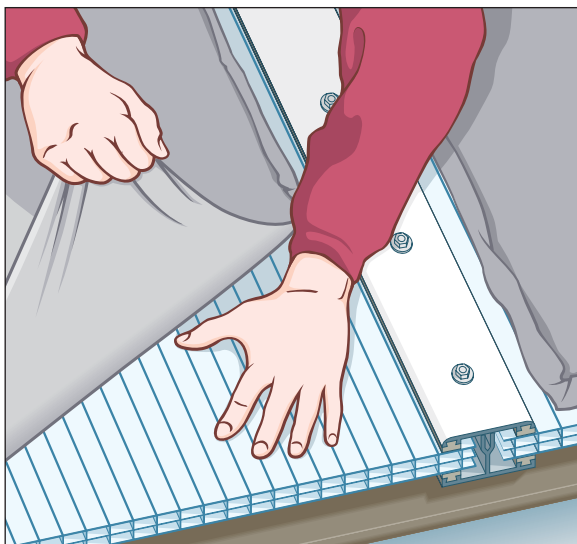

SAFETY - ROOF ACCESS

Do not walk on Marlon ST Longlife sheets at any time. Always use a crawling board placed across several support purlins of the structure.

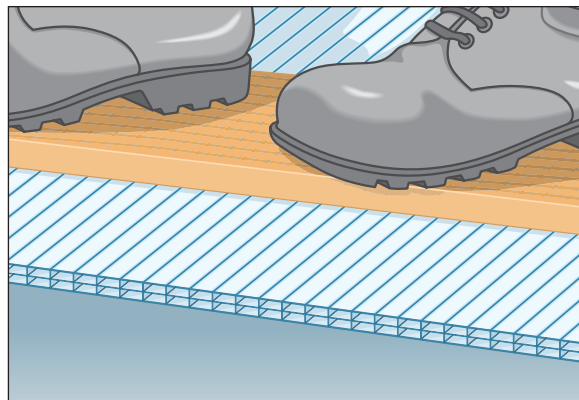

SAFETY - HANDLING

Sheets up to 3m long x 1m wide can be safely handled by one person but larger sheets will require two or more people. When handling and fitting sheets, particular care must be taken in windy conditions.

Any pallets of 6 metres or longer must be lifted using a spreader beam of adequate length (with no more than 2.5m unsupported at each end) or have the sheets removed by hand (one or two at a time) and re-stacked on a suitable pallet.

APPENDIX

CHEMICAL RESISTANCE

PAGE

19-22

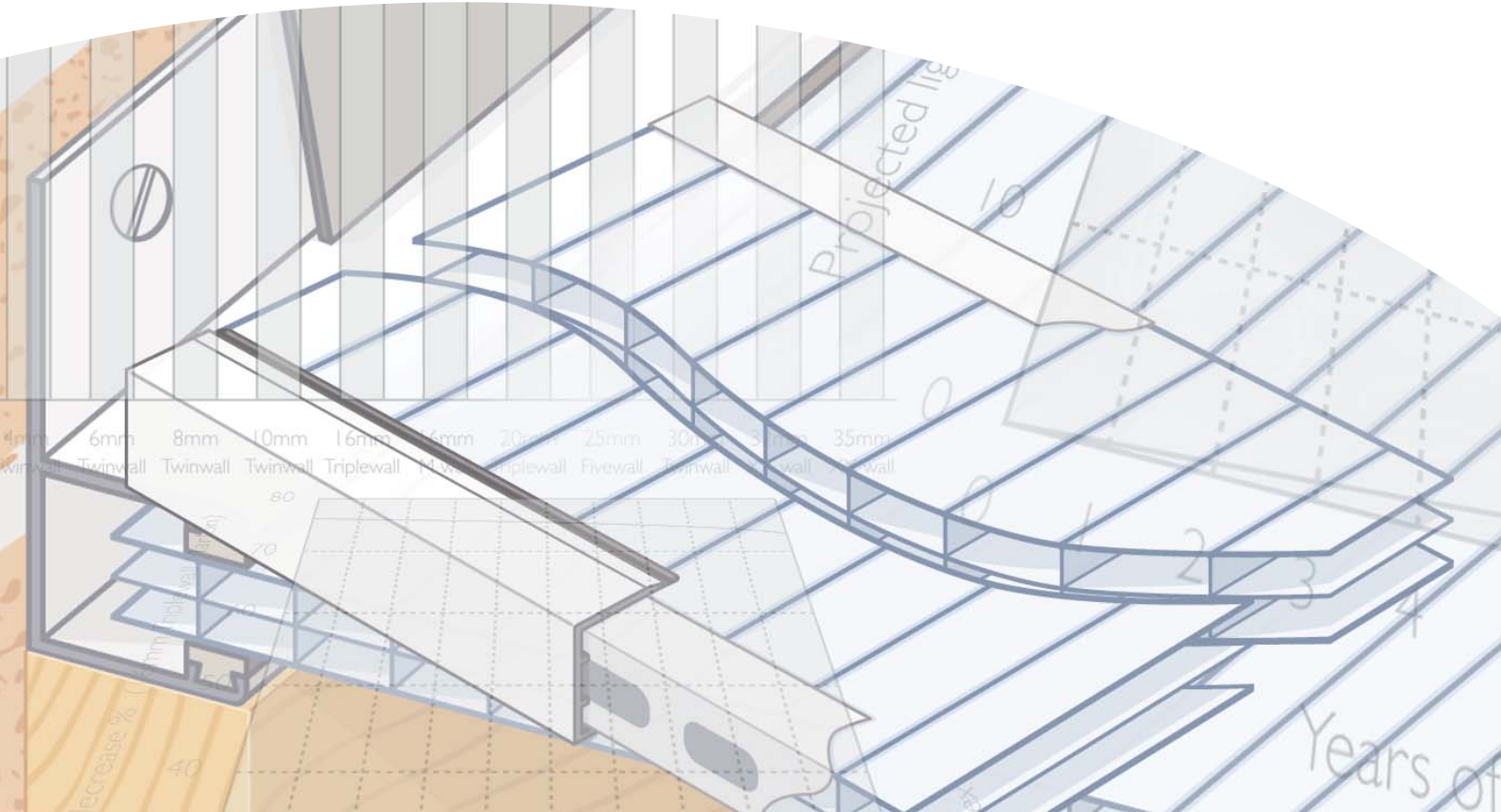

Marlon ST Longlife polycarbonate sheeting has, in general, excellent resistance to most chemicals. It is, however, difficult to simulate the sheer breadth of potential exposure conditions to which the sheet will be subjected in application.

The chemical resistance of Marlon ST Longlife depends not only on the actual chemical agent but also on the concentration, temperature, length of contact, pressure and the level of stress within the material.

Tabulated below are the chemical resistances of Marlon ST Longlife to a range of chemicals at 23°C : these are typical for unstressed and unloaded samples immersed for six months in a solution of the chemical.

I. CHEMICALS

- acetaldehyde
- + acetic acid up to 10%
- acetone
- + acetylene
- acrylonitrile
- allyl alcohol
- + alum
- + aluminium chloride, saturated solution in water
- + aluminium oxalate
- + aluminium sulphate, saturated solution in water
- ammonia
- + ammonium chloride, saturated solution in water
- ammonium fluoride, saturated solution in water
- ammonium hydroxide solution
- + ammonium nitrate, saturated solution in water
- + ammonium sulphate, saturated solution in water
- amyl acetate
- aniline
- + antimony chloride, saturated solution in water
- + arsenic acid, 20%
- benzaldehyde
- benzene
- + potassium chloride, saturated solution in water
- potassium cyanide
- + potassium dichromate, saturated solution in water
- + potassium metabisulphite, 4% in water
- + potassium nitrate, saturated solution in water
- + potassium perchlorate, 10% in water
- + potassium permanganate, 10% in water
- + potassium persulphate, 10% in water
- + potassium rhodanide, saturated solution in water
- + potassium sulphate, saturated solution in water
- + propane gas
- + propargyl alcohol
- propionic acid, conc.
- + propionic acid, 20%
- + propyl alcohol
- pyridine
- + resorcinol solution, 1%
- + silicofluoric acid, 30%
- + soda
- + sodium bicarbonate, saturated solution in water
- + sodium bisulphate, saturated
- + sodium bisulphite, saturated solution in water
- + sodium carbonate, saturated solution in water
- + sodium chlorate, saturated solution in water
- + sodium chloride, saturated solution in water
- + sodium hypochlorite, 5% solution in water
- + sodium sulphate, saturated solution in water
- sodium sulphide, saturated solution in water
- styrene
- + sublimate, saturated solution in water
- + sulphur
- sulphur dioxide
- sulphuric acid, conc.
- + sulphuric acid, 50%
- sulphuric acid, 70%
- sulphurous acid, 10%
- sulphuryl chloride
- + tartaric acid, 10%
- tetrachloroethane
- tetraethyllead, 10% in petroleum spirit
- tetrahydrofuran
- Tetralin
- thiophene
- toluene
- trichloroacetic acid, 10%
- trichloroethyl amine
- trichloroethylene
- trichloroethyl phosphate (plasticizer)
- tricresyl phosphate (plasticizer)
- + urea, saturated solution in water
- + water
- xylene
- + zinc chloride, saturated solution in water
- + zinc oxide
- + zinc sulphate, saturated solution in water

KEY :

+ good resistance ○ limited resistance - no resistance

2. DISINFECTANTS

- + Baktol®, 5%
- carbolic acid
- + chloroamine
- DDT
- + Delegol®, 5%
- Dimamin T, 5%
- + hydrogen peroxide
- iodine, tincture
- + Lysoform, 2%
- TB-Lysoform
- + Maktol®
- + Merfen®, 2%
- + Oktozon®, 1%
- + Perhydrol
- + resorcinol solution, 1%
- Sagrotan, 5%
- + spirit, pure
- + sublimate
- + Trosilin G extra®, 1.5%
- Zephirol®

3. PHARMACEUTICALS, COSMETICS

- + blood plasma
- + Delial® Sun Milk
- iodine, tincture
- + lanolin
- menthol, 90% in alcohol
- nail varnish
- nail varnish remover
- + Odol® mouthwash
- + Periston blood substitute
- + vaseline
- + Vick® Vapour Rub

4. FOODSTUFFS, DRINKS AND TOBACCO

- allspice
- + apple juice
- + beef tallow
- + beer
- + beet syrup
- + butter
- + chocolate
- + cinnamon
- cloves
- + cod-liver oil
- + coffee
- + cognac, 38%
- + cooking salt
- + edible oil
- + fish

- + fruit juices
- + fruit syrup (raspberry)
- + glucose
- + grapefruit juice
- + juniper schnapps
- lard
- + linseed oil
- + liqueurs
- + Maggi® sauce
- + margarine
- + meat
- + milk
- + mineral water
- + mustard
- nutmeg
- + onions
- + orange juice
- + paprika
- + pepper
- + rum
- + sugar solution, saturated
- + table salt
- + tea
- + tobacco
- + tomato juice
- + tomato purée
- + treacle
- + vanillin
- + vegetable oils
- + vinegar
- + vodka
- + water
- + wines
- + Worcester Sauce

5. DETERGENTS, RINSING AND CLEANING AGENTS

- + Ajax®
- + Calgonit® S, 1%
- Calgonit D, DM, DA, R
- Calgonit dishwashing liquid
- + Calgonit rinsing agent
- + Dor®
- + eau de javelle
- + Fewa®
- + Horolith M®
- Impact®, 0.2%
- + Into-Fensterklar®
- + laundry soap
- + Natril®
- Omo®

- + Parifex®, 2%
- Persil®
- + Pril®
- P 3 Asepto®
- Rapdosept®
- + Rei®
- + Riseptin®
- + Sidolin®
- + silicone oil emulsion
- + soft soap
- Somat W® 731
- + Suwa®
- + Trosilin F® extra, 2%
- Tuba carpet shampoo, conc.
- + WK 60® (Kron-Chemie)
- + Aral BG® 58
- + automatic switch grease
- + Baysilone Fluids (silicone fluids)
- + BP Energol HL 100®
- + BP Energol EM 100®
- + BP HLR 65®
- brake fluid (ATE)
- + burnishing oil (Brunofix)
- + cable insulating oil IG 1402
- + cable insulating oil KH 190
- + calcium soap fat
- camphor oil
- + castor oil
- + Darina® lubricating grease R2
- diesel oil
- drilling oil
- + Esso Estic 42-45®
- + fish liver oil
- + fish oil
- fuel oil (heating oil)
- + hydraulic fluid (Vac HLP 16)
- jet fuel JP 4 (b.p. 97-209°C)
- + Mobil DTE Oil Light®
- + Mobil Special Oil 10 W 30®
- + Molikote® paste
- + Molikote powder
- + naphthenic lubricating oil
- + paraffin base lubricating oil
- + paraffin oil
- + Polyran MM® 25 (lubricating oil)
- + rapeseed oil
- + Rhenocalor N®
- + sewing machine oil
- + Shell Spirax 90 EP®

KEY :

- + good resistance
- limited resistance
- no resistance

- Shell Tellus 11-33®
- + Shell Tellus 33®
- + silicone oil
- Skydrol 500 A®
- + sodium soap fat
- + Texaco Regal Oil BRUO®
- + Texaco Regal Oil CRUO®
- turpentine oil
- + turpentine substitute
- Valvoline WA 4-7
- varnish

6. ADHESIVES AND SEALANTS

- all-purpose adhesive
- + Cellux® adhesive films
- + galzier's putty
- + gypsum
- + insulating tape
- + Perbunan C®
- + rubber (free of plasticizer)
- + Terostat®
- + Tesafilm®
- + Tesamoll®

7. POLISHES AND ANTI-STATIC AGENTS

- Arquad 18®, 50%
- + Delu® anti-static solution
- + Persoftal®, 2%
- + Perspex Polish 3®
- + Plexiklar®
- benzoic acid
- benzyl alcohol
- + borax, saturated solution in water
- + boric acid
- bromine
- bromobenzene
- + butane (liquid and gaseous)
- butyl acetate
- + butyl alcohol
- + butylene glycol
- butyric acid
- + calcium chloride, saturated solution in water
- + calcium hypochlorite
- + calcium nitrate, saturated solution in water

- + calcium soap fat pure
- + carbon dioxide, moist
- carbon disulphide
- + carbon monoxide
- caustic potash
- caustic potash solution
- caustic soda
- caustic soda solution
- + chlorinated lime paste
- + chlorinated lime solution, 2% in water
- chlorine gas, dry
- chlorine gas, moist
- chlorobenzene
- chloroform
- + chrome alum, saturated solution in water
- + chromic acid, 20% in water
- + citric acid, 10%
- + coal gas
- + copper sulphate, saturated in water
- cresol
- + cupric chloride, saturated solution in water
- + cuprous chloride, saturated solution in water
- cyclohexanol
- cyclohexanone
- + Dekalin
- diamyl phthalate
- dibutyl phthalate (plasticizer)
- diethyl ether
- + diethylene glycol
- + diglycolic acid, saturated in water
- dimethylformamide
- dinonyl phthalate (plasticizer)
- dioctyl phthalate (plasticizer)
- dioxane
- diphyl 5,3
- + ethanol
- ether
- + ethyl alcohol, 96% pure
- ethyl amine
- ethyl bromide
- ethylene chloride
- ethylene chlorohydrin
- + ethylene glycol

- + ferric chloride, saturated solution in water
- + ferrous sulphate
- + Formalin, 10%
- formic acid, 30%
- glycerol
- + glycol
- + heptane
- + hexane
- hydrochloric acid, conc.
- + hydrochloric acid, 20%
- hydrofluoric acid, conc.
- + hydrofluoric acid, 5%
- + hydrogen peroxide, 30%
- + hydrogen sulphide
- iodine
- isoamyl alcohol
- isopropyl alcohol
- + lactic acid, 10% solution in water
- + ligroin (hydrocarbon mixture)
- + magnesium chloride, saturated solution in water
- + manganese sulphate, saturated solution in water
- + mercuric chloride, saturated
- + mercury
- + methane
- + methanol
- methyl amine
- methylene chloride
- methyl ethyl ketone
- methylmethacrylate
- milk of lime, 30% suspension in water
- + nitric acid, 10%
- nitric acid, 10-20%
- nitric acid, 20%
- nitrobenzene
- nitrous fumes, dry
- + oleic acid, conc.
- + oxalic acid, 10% in water
- + oxygen
- + ozone
- + pentane
- perchloric acid, conc.
- + perchloric acid, 10% in water
- perchloroethylene
- + Perhydrol, 30%

KEY :

- + good resistance
- limited resistance
- no resistance

- petroleum
- petroleum ether (hydrocarbon mixture)
- + petroleum spirit (for dry cleaning, free of aromatics)
 - phenol
 - phenylethyl alcohol
- + phosphorus oxychloride
- phosphorus trichloride
- + potassium aluminium sulphate, saturated solution in water
- + potassium bromide, saturated solution in water
- + potassium carbonate, saturated solution in water
- + Polifac® grinding paste
- + Stalexan AN®

8. INKS

- + Geha stamping ink
- Multi-Marker (Faber Castell)
- + Pelican Royal Blue 4001
- + Visor Pen 7 blue

9. MISCELLANEOUS

- + Basilit® UAK, 20% in water (wood preservative)
- + Battery acid
- + blood
- + castor oil
- + cement
- + Chrome Oxide Green (grinding paste)
- + cleaning petrol
- + coal gas
 - E 605® conc.
- + E 605®, 0.5% (plant insecticide)
- + exhaust fumes, acidic
- + Final photographic developer, diluted ready for use
- + floor polish
- + Freon® TF
- + Freon® T-WD 602
- + Frigen® 113TRT
- + gypsum
- + insulating tape
- + Kaltron® 113 MDR
 - kerosene (aviation fuel)
 - Metasystox®, 0.5% (insecticide)
 - motor fuel, high-octane

- motor fuel, ordinary grade
- + natural rubber
- + Nekal BX®, 2% (wetting agent)
- + Neutol photographic developer, diluted ready for use
- + Orthozid® 50, 0.5% (fungicide)
- + perspiration, acid (pH 4.7)
- perspiration, alkaline (pH 9.5)
- + PLK 4 (wood preservative)
- + polyamide
- + polyethylene
- polymeric plasticizers
- + polyvinyl chloride
- polyvinyl chloride, containing plasticizer
- + sea water
 - Shell IP 4 (fuel)
- soap suds
- + starch
- Tanigan® CLS, 30%
- Tanigan® CV
 - tannic acid
 - white spirit

KEY :

+ good resistance ○ limited resistance - no resistance

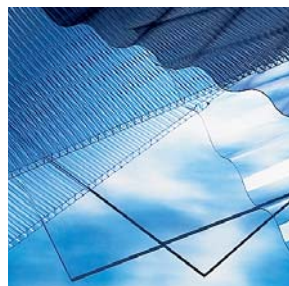

Brett Martin's Marlon brand of polycarbonate includes ranges of flat, profiled and multi wall sheets.

Brett Martin Ltd

24 ROUGHFORT ROAD
MALLUSK, CO ANTRIM
UK, BT36 4RB

TEL: +44 (0) 28 9084 9999

FAX: +44 (0) 28 9083 6666

Email: mail@brettmartin.com

All reasonable care has been taken in the compilation of the information contained within this literature. All recommendations on the use of our products are made without guarantee, as conditions of use are beyond the control of Brett Martin. It is the customer's responsibility to ensure that the product is fit for its intended purpose and that the actual conditions of use are suitable. Brett Martin pursues a policy of continuous product development and reserves the right to amend specifications without prior notice. The photographs used are for illustration purposes only and simply indicate possible uses of Marlon ST.



Certificate No. Q09125

BS EN ISO 9001:2000

BRETT MARTIN 

930RP03071

FOR THE LATEST INFORMATION VISIT THE COMPANY'S WEB SITE:

www.brettmartin.com